

标记	文件号	修改内容	签名	日期

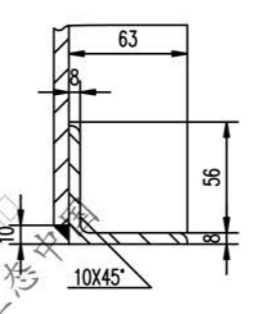
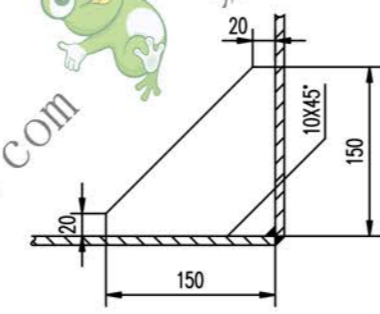
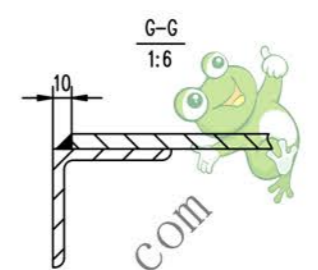
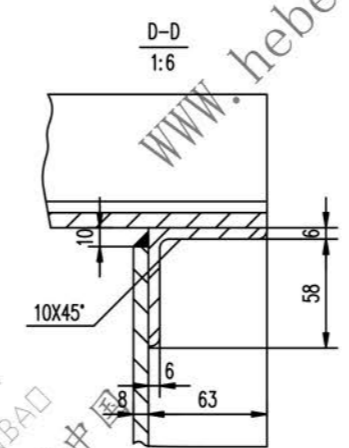
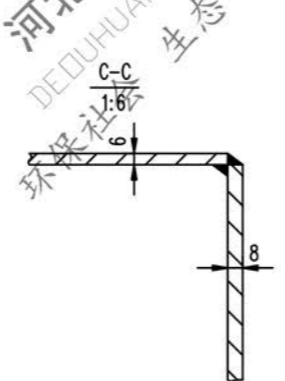
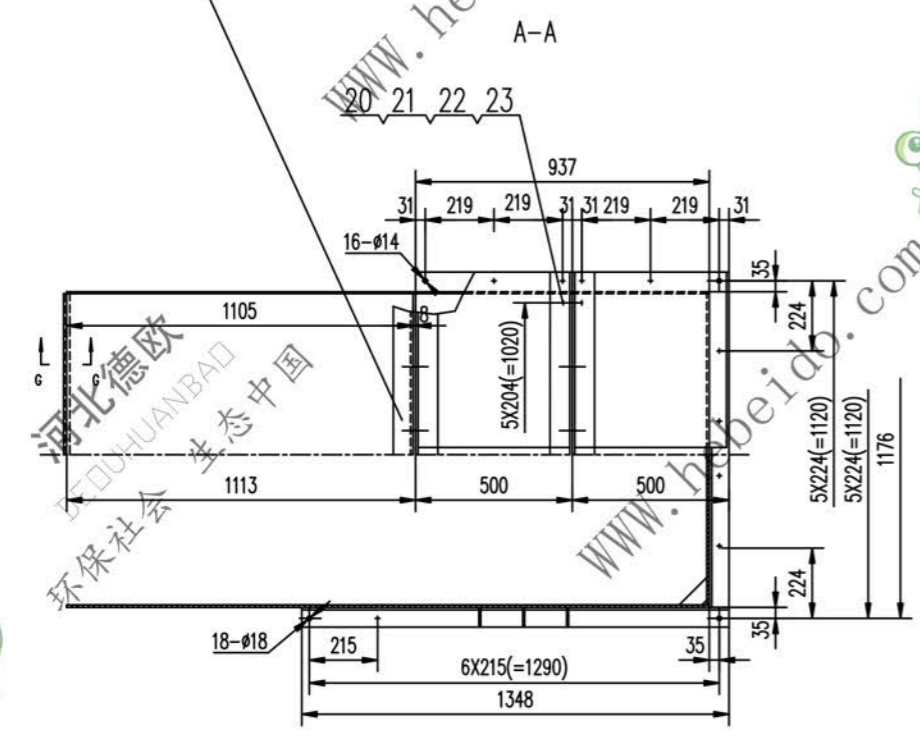
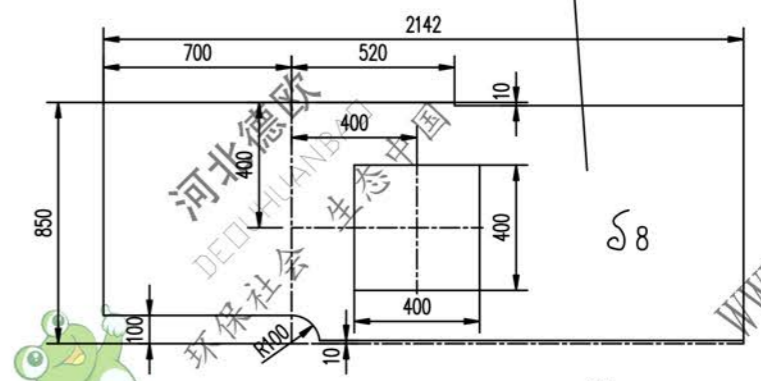
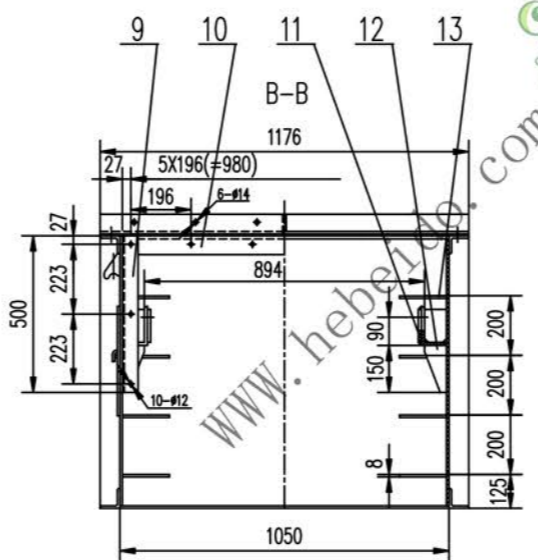
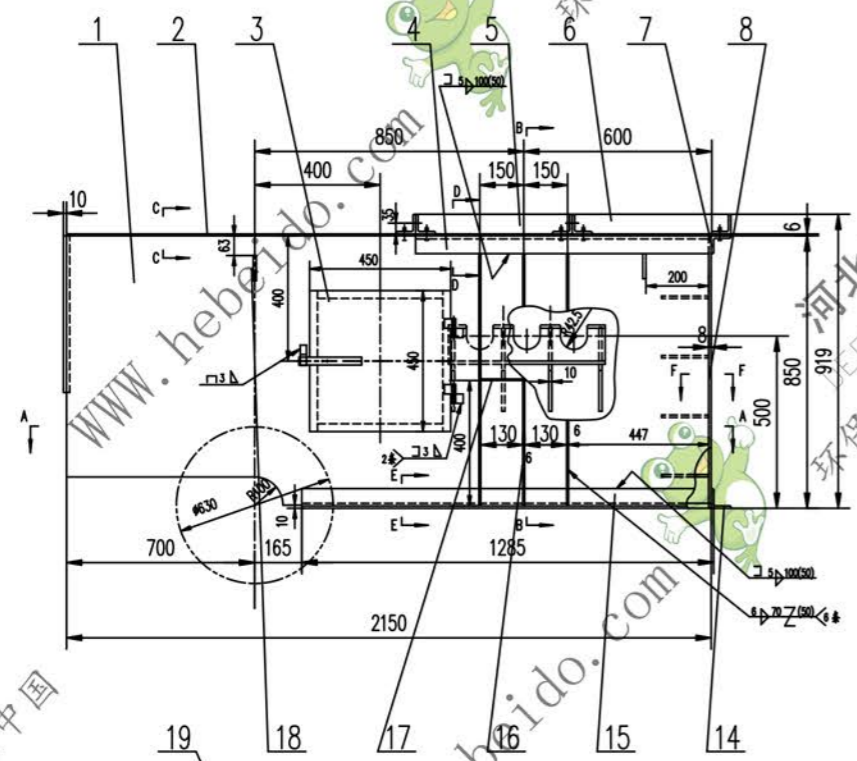

- 技术要求
1. 钢材下料切割面粗糙度
 2. 所有孔应配钻, 粗糙度
 3. 未注焊缝均为连接角焊, 焊角高为被焊件最小厚度

23	GB97.1-86	垫圈 12	28		0.005	0.14	
22	GB93-87	垫圈 12	28		0.004	0.112	
21	GB41-86	螺母 M12	28		0.016	0.448	
20	GB5780-86	螺栓 M12X35	28		0.36	0.08	
19		角钢 63X63X6-1176	1	Q235-A	6.728	6.728	
18		钢板 $\delta 10$	4	Q235-A	0.435	1.74	
17		钢板 $\delta 6$	4	Q235-A	0.478	1.912	
16		钢板 $\delta 6$	6	Q235-A	2.459	4.754	
15		角钢 63X63X8-1348	2	Q235-A	10.068	20.136	
14		角钢 63X63X8-1050	1	Q235-A	7.842	7.842	
13		钢板 $\delta 8$	8	Q235-A	0.85	6.8	
12		钢板 $\delta 10$	8	Q235-A	0.471	3.768	
11		支架	2	零件	14.001	28.002	
10		角钢 50X50X5-934	1	Q235-A	3.521	3.521	
9		角钢 50X50X5-500	2	Q235-A	1.885	3.77	
8		钢板 8X750X1034	1	Q235-A	53.552	53.552	
7		角钢 63X63X6-1176	1	Q235-A	6.728	6.728	
6	II 03J22342.2.2	上盖 (-)	1	零件	41.727	41.727	
5	II 03J22342.2.1	上盖 (-)	1	零件	41.727	41.727	
4		角钢 63X63X6-937	2	Q235-A	5.361	10.722	
3	II 03J22241.2.1	观察门	2	零件	7.025	4.05	借用
2		钢板 6X1034X1205	1	Q235-A	58.311	58.311	
1		钢板 $\delta 8$	2	Q235-A	98.948	197.896	

序号	代号	名称	数量	材料	重量 (kg)	备注
合号						
II 03J22352.2						
图样标记 重量 kg 比例						
S 534.527 1:12						
共 72 页						
第 21 页						